

**Power PCB Relay T9S Solar**

- 1 pole 35A, 1 form A (NO) contact
- Contact gap >1.5mm
- 350mW hold power
- Ambient temperature up to 85°C at 35A
- The appliance is able to meet VDE V 0126-1-1
- Product in accordance to IEC 60335-1
- EN61095: AC7a at 85°C



f0156\_bc\_inv

Typical applications  
Photovoltaic inverter

**Approvals**

VDE 40030974, UL E58304  
Technical data of approved types on request

**Contact Data**

Contact arrangement	1 form A (NO)
Contact gap	>1.5mm
Rated voltage	277VAC
Rated current	35A <sup>1)</sup>
Breaking capacity max.	8750 VA
Contact material	AgNi
Initial contact resistance	75mΩ max. at 1A 6VDC
Frequency of operation, with/without load	6/300min <sup>-1</sup>
Operate/release time max., incl bounce time	18/15ms

**Contact ratings**

Type	Contact	Load	Cycles
<b>IEC 61610</b>			
T9SV1K15-12	A (NO)	35A, 250VAC, cosφ=1, 85°C	30x10 <sup>3</sup>
<b>UL 508</b>			
T9SV1K15-12	A (NO)	35A, 277VAC, resistive, 85°C	30x10 <sup>3</sup>

Mechanical endurance, DC coil 1x10<sup>6</sup> operations

1) The relay connections and wiring have to be designed with an adequate cross sections to ensure the current flow and heat dissipation.

**Coil Data**

Rated coil voltage	12VDC
Coil insulation system according UL	class F

**Coil versions, DC coil**

Coil code	Rated voltage VDC	Operate voltage VDC	Release voltage VDC	Coil resistance Ω±10%	Rated coil power W
12	12 <sup>2)</sup>	9.6	0.8	64±10%	2.25 / min. 0.35 hold

2) After the energization time of 50 ms with 12 VDC the coil requires a reduction of the coil voltage to 4.7...6.0 VDC.

All figures are given for coil without pre-energization, at ambient temperature +23°C. Other coil voltages on request.

**Insulation Data**

Initial dielectric strength	
between open contacts	2500V <sub>rms</sub>
between contact and coil	4000V <sub>rms</sub>
Clearance/creepage	
between contact and coil	3/4mm
Material group of insulation parts	III
Tracking index of relay base	PTI 325

**Other Data**

Material compliance: EU RoHS/ELV, China RoHS, REACH, Halogen content refer to the Product Compliance Support Center at [www.te.com/customer-support/rohssupportcenter](http://www.te.com/customer-support/rohssupportcenter)

Ambient temperature	-40 to +85°C <sup>1)</sup>
Category of environmental protection	
IEC 61810	RTII - flux proof
Vibration resistance (functional)	10g
Shock resistance (functional)	10g
Shock resistance (destructive)	100g
Terminal type	PCB-THT
Mounting	see note <sup>1)</sup>
Mounting distance	≥10mm
Weight	appr. 30g
Resistance to soldering heat THT	
IEC 60068-2-20	260°C/5s
Packaging unit	box/500 pcs.

1) The relay connections and wiring have to be designed with an adequate cross sections to ensure the current flow and heat dissipation.

**Power PCB Relay T9S Solar** (Continued)

**Dimensions**

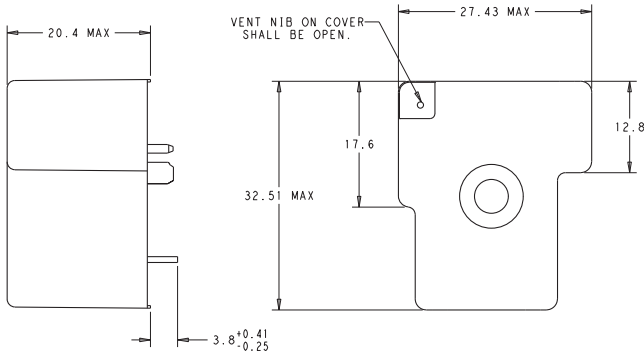

**PCB layout / terminal assignment**

Bottom view on solder pins

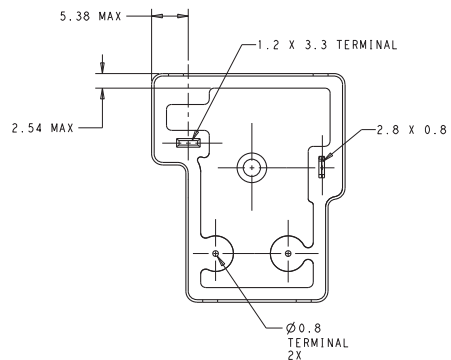
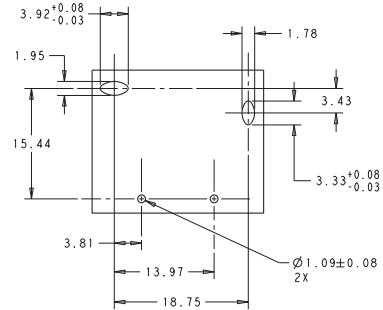

WIRING DIAGRAM (BOTTOM VIEW)

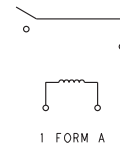

**Notes**

**1) General tolerance**

Diagram Dimension	Tolerance
< 1 mm	±0.1
1 ~ 3 mm	±0.2
> 3 mm	±0.3

**2) Dimensions of the pins after tin soldering**

- a) +0.4 for the width and the thickness
- b) +1.0 for the length

Product code	Version	Contact arrangement	Contact material	Coil	Part number
T9SV1K15-12	PCB, flux tight	1 form A (NO) contact	AgNi	12VDC	2027395-1