

NOTES:

1. ALL DIMENSIONS ARE SHOWN IN INCH.
2. MATERIAL: NYLON-66, FLAMMABILITY UL94-V2. BLACK COLOR.
3. P.C. BOARD HOLE DIAMETER RANGE: 0.116"(2.94mm) ~ 0.120"(3.04mm).
4. HEAT SINK HOLE DIAMETER: $0.135^{+0.003}_{-0.000}$
5. LINK BROKEN IS ACCEPTED, NO FUNCTION DEFECT.
6. COMPLY WITH EU RoHS DIRECTIVE.
7. 83FT12-XX-9909, THE XX IS FOR SPRING CODE NUMBER.

REV	DESCRIPTION	DATE	DRAWN
1	RELEASE FOR PRODUCTION	FEB-21-2012	Chris

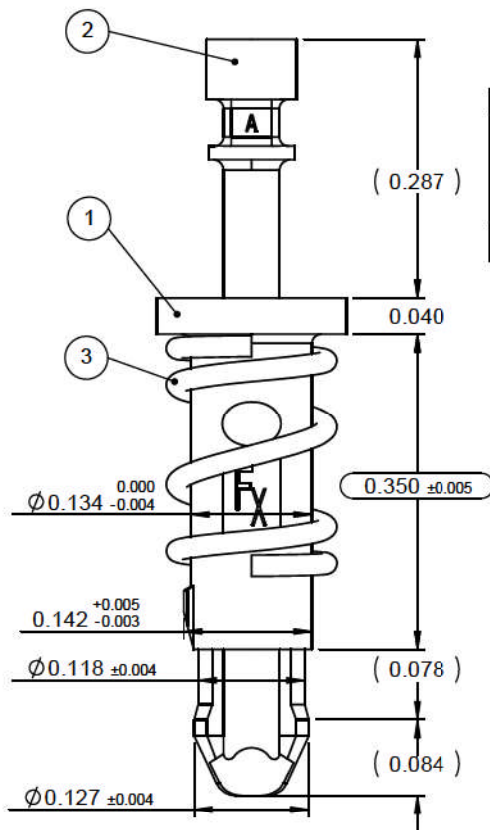
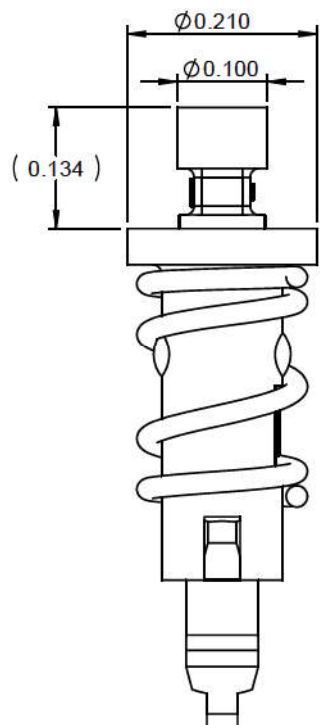

SPRING SPEC								Mark
SPRING P/N	SPRING CODE	A $\pm^{0.028}_{-0.004}$ (inch)	$\phi B \pm 0.002$ (inch)	$\phi C \pm^{0.008}_0$ (inch)	Total Coils	Force Rate (lbf/in)	Material	
52FT20-00-4010	20	0.268	0.024	0.142	4.00	31.4	SUS304	

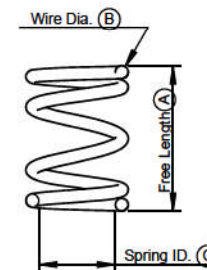

3	1	52FTXX-00-4010	SPRING
2	1	39FT80-00-2099	PIN
1	1	39FT73-00-2099	BODY
-	1	83FT12-xx-9909	83FT12-XX FASTENER ASSEMBLY
NO.	-003 -002 -001	QTY PER ASSY	PART NUMBER
			DESCRIPTION

MATERIAL : SEE NOTE
 PROJ. NO.: FT1207

UNLESS OTHERWISE SPECIFIED
 TOLERANCES IN ACCORDANCE WITH ASME Y14.5M-1994
 DIMENSIONS ARE IN INCH TOLERANCES:
 ALL Angles $\pm 2^\circ$
 ALL DIMENSION $\pm 0.010^\circ$



This print and any design thereon is the property of ITW-ASIA, Division Illinois Tool Works Inc. This print is to be returned upon request or completion of the work for which it was issued. It is to be used only for the purpose for which it was expressly loaned and is not to be copied in any manner, nor is information taken therefrom to be transmitted, or passed on to others without written permission of Illinois Tool Works Inc.

PART NAME: 83FT12-xx SERIES FASTENER	REV 1
PART NUMBER: 83FT12-XX-9909	SHEET 1/1

DRAWN BY Chris	DATE FEB-21-2012
CHK BY Marvin	DATE FEB-21-2012
APP BY Casey	DATE FEB-21-2012

- " " MARK DIMENSION NEED TO BE MEASURED FOR FQC INSPECTION.
- " " MARK FOR CPK WHEN SUBMIT FAI.
- " () " MARK FOR REFERENCE DIMENSION.

THE DRAWING CONTAIN ITW CORPORATION CONFIDENTIAL INFORMATION. IT IS DISCLOSED IN CONFIDENCE AND ITS CONTENTS MAY NOT BE DISCLOSED, REPRODUCED, DISPLAYED OR MODIFIED, WITHOUT THE PRIOR WRITTEN CONSENT OF ITW CORPORATION.
 此圖含ITW公司之機密文件,若無正式核准不得轉露複製展示或修改之。