

PROLABS – SFP-GE-L-C

1.25GBd SFP (Small Form Pluggable) Long Wavelength (1310nm) Transceiver

SFP-GE-L-C Overview

ProLabs's SFP-GE-L-C SFP optical transceivers are based on Gigabit Ethernet IEEE 802.3 standard and Fiber Channel FC-PI Rev.5.0 and provide a quick and reliable interface for the GE/FC application. In addition, they comply with the Small Form Factor Pluggable Multi Sourcing Agreement (MSA).

Product Features

- Up to 1.25 GBd bi-directional data links
- Compliant with IEEE 802.3z Gigabit Ethernet and 1000BASE-LX
- Compliant with SFP MSA
- Hot-pluggable SFP footprint
- 1310nm Fabry-Perot laser transmitter
- Duplex LC connector
- Up to 10-20km on 9/125um SMF
- Single power supply 3.3V
- RoHS Compliance
- Class 1 laser product complies with EN 60825-1
- Operating temperature range: 0°C to 70°C.

Applications

- 1.25 GBd Gigabit Ethernet
- 1.063 GBd Fiber Channel
- Compatible with Cisco SFP-GE-L

Ordering Information

<i>Part Number</i>	<i>Description</i>
SFP-GE-L-C	GE/FC SFP 1310nm LC Connectors 10km on SMF.

General Specifications

<i>Parameter</i>	<i>Symbol</i>	<i>Min</i>	<i>Typ</i>	<i>Max</i>	<i>Unit</i>	<i>Remarks</i>
Data Rate	<i>DR</i>		1.25		GBd	IEEE 802.3
			1.062			FC-PI-2 Rev 5
Bit Error Rate	<i>BER</i>			10^{-12}		
Operating Temperature	<i>T_{OP}</i>	0		70	°C	Case temperature
Storage Temperature	<i>T_{STO}</i>	- 40		85	°C	Ambient temperature
Supply Current	<i>I_S</i>		175	300	mA	For electrical power interface
Input Voltage	<i>V_{CC}</i>	3	3.3	3.6	V	
Maximum Voltage	<i>V_{MAX}</i>	- 0.5		4	V	For electrical power interface

Optical Characteristics – Transmitter

$V_{CC}=3V$ to $3.6V$, $T_C=0^{\circ}C$ to $70^{\circ}C$

Parameter	Symbol	Min	Typ	Max	Unit	Remarks
Output Optical Power	P_{TX}	- 9.5		- 3	dBm	Class 1 Product
Optical Center Wavelength	λ_C	1270		1360	nm	
Optical Modulation Amplitude	OMA	174			uW	Equivalent extinction ratio specification for FC
Extinction Ratio	ER	9			dB	
Spectral Width (RMS)	$\Delta\lambda$			3	nm	
Optical Rise/Fall Time (20% - 80%)	T_{RF_IN}		150	260	ps	
Relative Intensity Noise	RIN			- 120	dB/Hz	
Deterministic Jitter Contribution	TX_ADJ		20	56.5	ps	
Total Jitter Contribution	TX_ATJ		50	119	ps	

Optical Characteristics – Receiver

$V_{CC}=3V$ to $3.6V$, $T_C=0^{\circ}C$ to $70^{\circ}C$

Parameter	Symbol	Min	Typ	Max	Unit	Remarks
Optical Receiver Power	P_{RX}			0	dBm	Average
Optical Center Wavelength	λ_C	1265		1600	nm	
Receiver Sensitivity @ 1.063GBd	R_{X_SEN1}			- 21	dBm	FC-PI-2 Rev.5
Receiver Sensitivity @ 1.25GBd	R_{X_SEN2}			- 19	dBm	IEEE 802.3
Stressed Rx Sens @ 1.25GBd				- 14.5	dBm	IEEE 802.3
Optical Return Loss	ORL	12			dB	
Receiver Electrical 3dB Upper cutoff frequency				1500	MHz	
Loss of Signal-Asserted	P_{LOS_A}	- 30			dBm	
Loss of Signal-Deasserted	P_{LOS_D}			- 19	dBm	
Loss of Signal-Hysteresis		0.5			dB	

Electrical Characteristics – Transmitter

$V_{CC}=3V$ to $3.6V$, $T_C=0^{\circ}C$ to $70^{\circ}C$

Parameter	Symbol	Min	Typ	Max	Unit	Remarks
Input differential impedance	R_{IN}		100		Ω	Non condensing
Single ended data input swing	V_{IN_PP}	250		1200	mV	
Transmit disable voltage	V_D	$V_{CC}-1.3$		V_{CC}	V	
Transmit enable voltage	V_{EN}	V_{EE}		$V_{EE}+0.8$	V	
Transmit disable assert time				10	us	

Electrical Characteristics – Receiver

$V_{CC}=3V$ to $3.6V$, $T_C=0^{\circ}C$ to $70^{\circ}C$

Parameter	Symbol	Min	Typ	Max	Unit	Remarks
Single ended data output swing	V_{OUT_PP}	300	400	800	mV	
Data output rise/fall time (20%-80%)	T_R			300	ps	
LOS Fault	V_{LOS_Fault}	$V_{CC}-0.5$		$V_{CC_HO_ST}$	V	
LOS Normal	V_{LOS_normal}	V_{EE}		$V_{EE}+0.5$	V	
Power Supply Rejection	PSR	100			mV _{PP}	
Deterministic Jitter Contribution	RX_ADJ			80	ps	
Total Jitter Contribution	RX_ATJ			122.4	ps	

Block Diagram of Transceiver

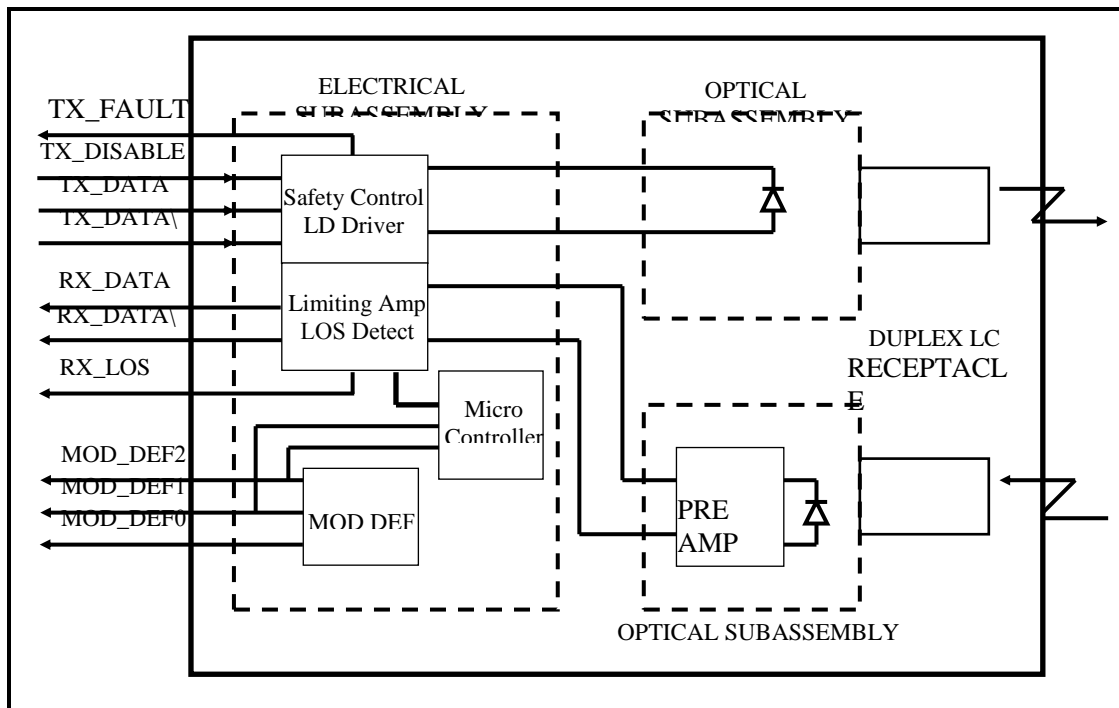

Transmitter Section

The FP driver accept differential input data and provide bias and modulation currents for driving a laser. An automatic power-control (APC) feedback loop is incorporated to maintain a constant average optical power. 1310 nm FP in an eye safe optical subassembly (OSA) mates to the fiber cable.

TX_DISABLE

The TX_DISABLE signal is high (TTL logic "1") to turn off the laser output. The laser will turn on within 1ms when TX_DISABLE is low (TTL logic "0").

TX_FAULT

When the TX_FAULT signal is high, output indicates a laser fault of some kind. Low indicates normal operation.

Receiver Section

The receiver utilizes a PIN detector integrated with a trans-impedance preamplifier in an OSA. This OSA is connected to a Limiting Amplifier which providing post-amplification quantization, and optical signal detection. The limiting Amplifier is AC-coupled to the transimpedance amplifier, with internal 100Ω differential termination.

Receive Loss (RX_LOS)

The RX_LOS is high (logic "1") when there is no incoming light from the companion transceiver. This signal is normally used by the system for the diagnostic purpose. The signal is operated in TTL level.

Controller Section

The micro controller unit monitors the operation information of LD driver and Limiting Amplifier. And report these status to the customer.

Dimensions

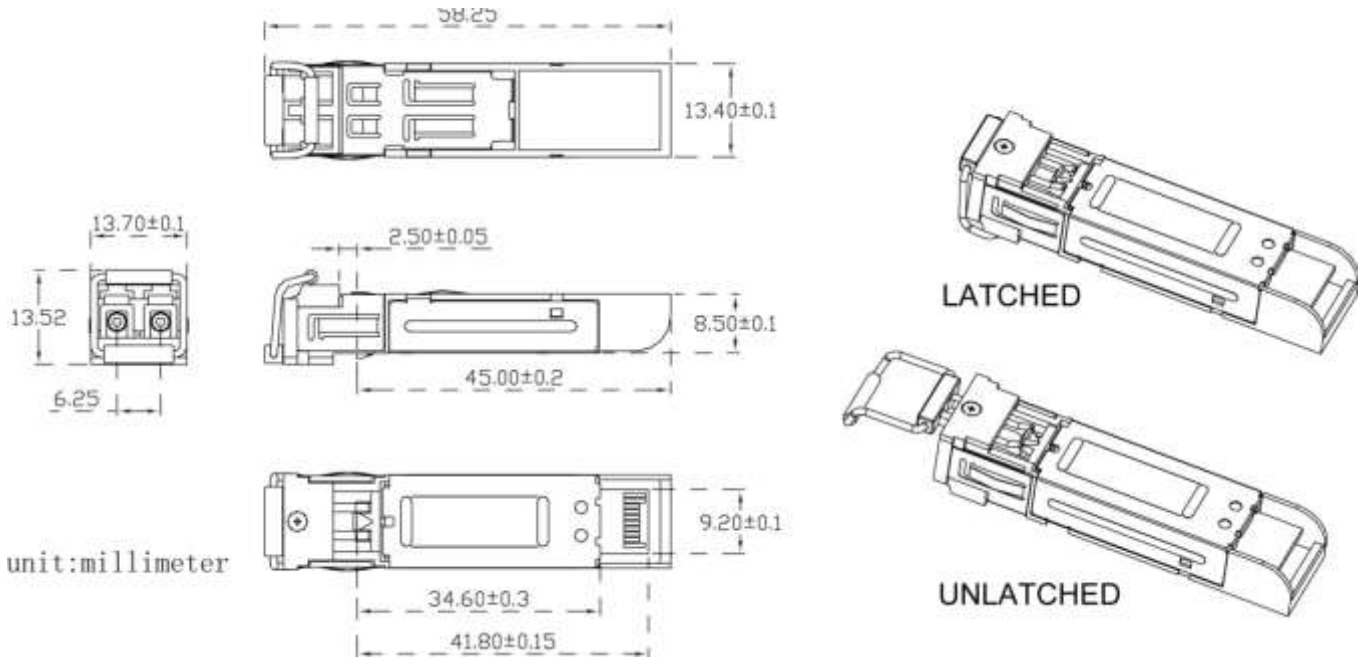

**ALL DIMENSIONS ARE ± 0.2 mm UNLESS OTHERWISE SPECIFIED
UNIT: mm**

PCB Layout Recommendation

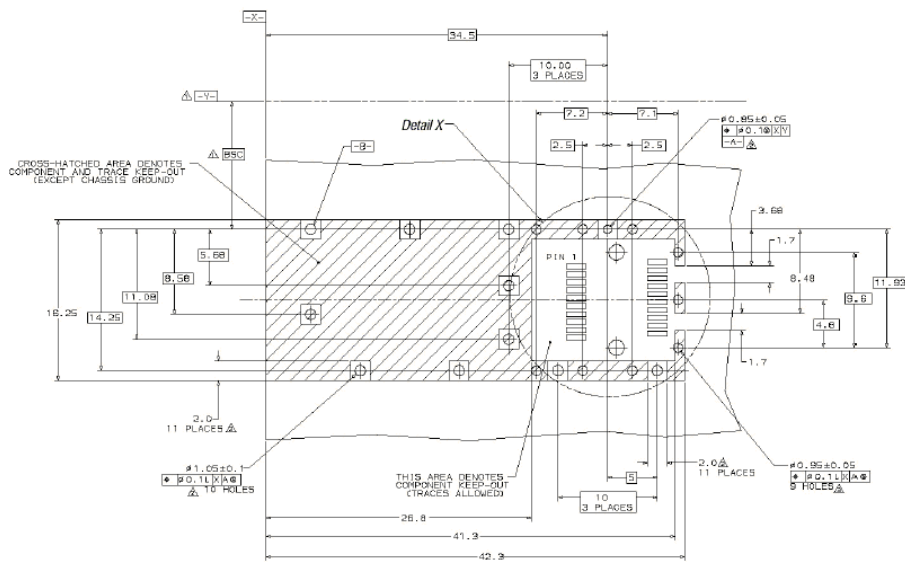

- △ Datum and Basic Dimension Established by Customer
- △ Pads and Vias are Chassis Ground, 11 Places
- △ Through Holes are Unplated

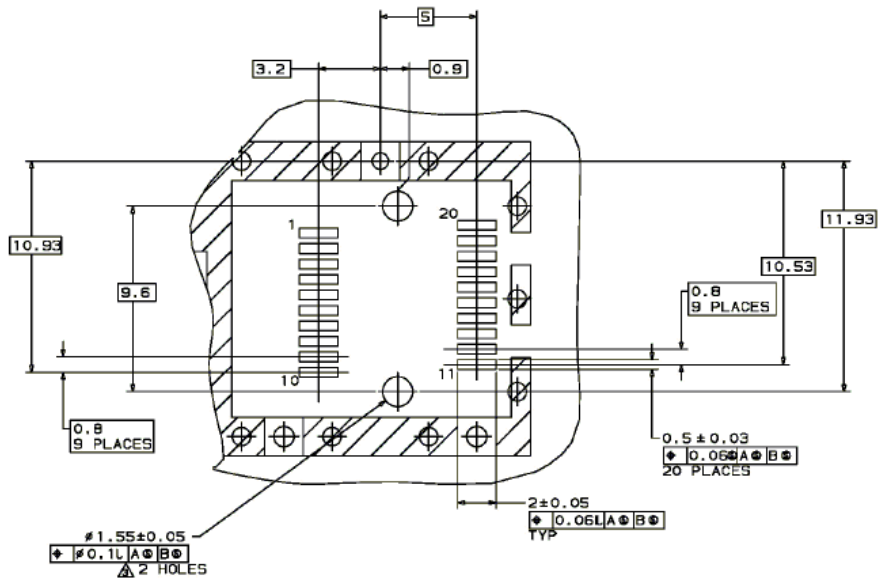

Pin Assignment

PIN #	Symbol	Description	Remarks
1	V_{EET}	Transmitter ground (common with receiver ground)	Circuit ground is isolated from chassis ground
2	T_{FAULT}	Transmitter Fault. Not supported	
3	T_{DIS}	Transmitter Disable. Laser output disable on high or open	Disabled: $T_{DIS} > 2V$ or open Enabled: $T_{DIS} < 0.8V$
4	MOD_DEF (2)	Module Definition 2. Data line for serial ID	Should Be pulled up with 4.7k – 10k ohm on host board to a voltage between 2V and 3.6V
5	MOD_DEF (1)	Module Definition 1. Clock line for serial ID	
6	MOD_DEF (0)	Module Definition 0. Grounded within the module	
7	Rate Select	No connection required	
8	LOS	Loss of Signal indication. Logic 0 indicates normal operation	LOS is open collector output
9	V_{EER}	Receiver ground (common with transmitter ground)	Circuit ground is isolated from chassis ground
10	V_{EER}	Receiver ground (common with transmitter ground)	
11	V_{EER}	Receiver ground (common with transmitter ground)	
12	RD-	Receiver Inverted DATA out. AC coupled	
13	RD+	Receiver Non-inverted DATA out. AC coupled	
14	V_{EER}	Receiver ground (common with transmitter ground)	Circuit ground is isolated from chassis ground
15	V_{CCR}	Receiver power supply	
16	V_{CCT}	Transmitter power supply	
17	V_{EET}	Transmitter ground (common with receiver ground)	Circuit ground is connected to chassis ground
18	TD+	Transmitter Non-Inverted DATA in. AC coupled	
19	TD-	Transmitter Inverted DATA in. AC coupled	
20	V_{EET}	Transmitter ground (common with receiver ground)	Circuit ground is connected to chassis ground

References

1. IEEE standard 802.3. IEEE Standard Department, 2002.
2. Small Form Factor Pluggable (SFP) Transceiver Multi-Source Agreement (MSA), September 2000.
3. Fiber Channel Draft Physical Interface Specification (FC-PI-2 Rev.5).
4. Fiber Channel Physical and Signaling Interface (FC-PH/PH2/PH3).